



# TYPE 3710

## Cartridge Split Seal

# 3710

- A – Mating Ring
- B – Mating Ring/  
Retaining Ring
- C – Mating Ring/  
Clamp Ring
- D – Mating Ring  
Adapter
- E – Primary Ring
- F – Primary Ring/  
Retaining Ring
- G – Finger Springs
- H – Spring Retainer
- I – Gland O-Ring
- J – Flat Gasket
- K – Gland Assembly
- L – Shaft O-Ring

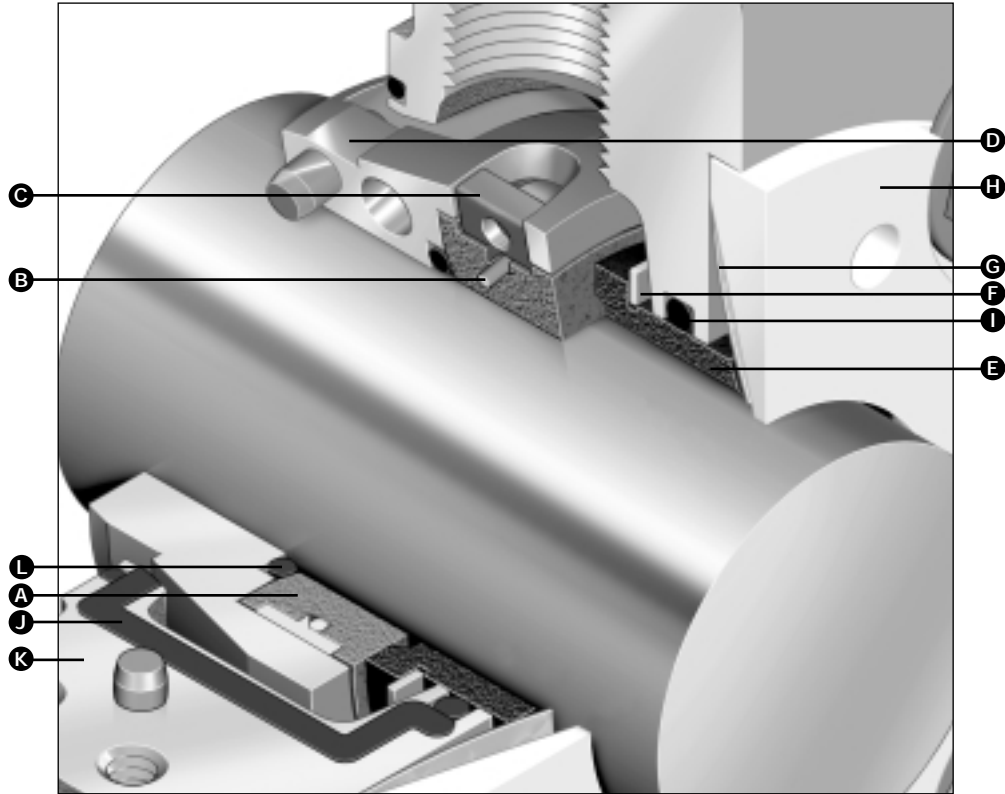

### Product Description

The Type 3710 Cartridge Split Seal is the latest innovation in the evolution of split seal designs.

- The Type 3710 fully split seal features a unique reliable design, which is the result of years of split seal experience in the marine and industrial markets.
- Type 3710 adapts to horizontal and vertical equipment.

### Design Features

- Simple, Reliable Assembly and Installation.
- Hydraulically Pressure-Balanced Design Ensures Seal Integrity During System Upsets.
- Unitized Finger Springs Are Nonclogging and Provide Positive Drive to the Seal Face.
- Various Seal Face and Elastomer Combinations for a Majority of Service Requirements.
- Field Repairable and Repair Kits Available.
- Two Connections in the Gland Provide Easy Access for Flush Piping.

### Performance Capabilities

- Temperature:  
Up to 121°C/250°F
- Pressure:  
Vacuum to 13.7 bar g/200 psig
- Speed:  
3600 rpm up to 62mm/2.500"  
1800 rpm for seal sizes between 62mm/2.500"  
and 135mm/5.250"  
900 rpm for seal sizes greater than 135mm/5.250"



# TYPE 3710

## Cartridge Split Seal

### Type 3710 Typical Arrangement/Dimensional Data

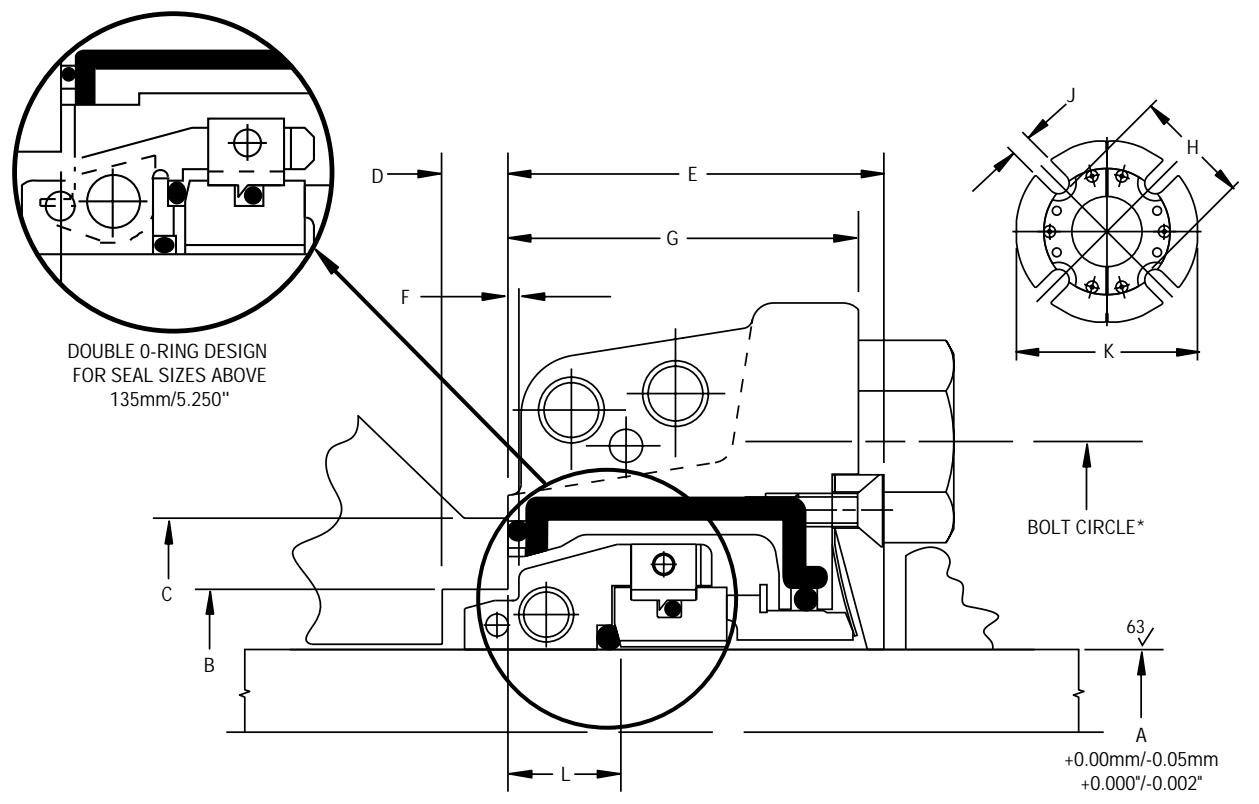

### Type 3710 Dimensional Data (mm)

Seal Dash Number	A +0.00/-0.05	B Min.	B Max.	C Min.	D Min.	E	F Set Dim.	G	H	J	K	L Min.
-040	40	63.50	68.25	74.60	10.34	47.70	1.59	44.45	82.58	15.85	134.11	12.79
-041	41	63.50	68.25	74.60	10.34	47.70	1.59	44.45	82.58	15.85	134.11	12.79
-045	45	63.50	68.25	74.60	10.34	47.70	1.59	44.45	82.58	15.85	134.11	12.79
-050	50	69.85	76.20	84.12	11.13	51.05	1.57	46.43	87.33	14.27	139.70	13.18
-053	53	73.03	82.55	92.08	7.94	55.58	1.57	50.80	100.08	16.67	155.58	16.20
-055	55	73.03	82.55	92.08	7.94	55.58	1.57	50.80	100.08	16.67	155.58	16.20
-060	60	80.98	95.25	104.78	9.53	54.48	1.59	50.80	104.75	19.05	165.10	15.86
-062	62	80.98	92.08	104.78	9.53	54.48	1.59	50.80	104.75	19.05	165.10	16.37
-065	65	92.08	109.52	120.65	9.53	60.31	1.57	53.98	120.65	19.05	184.15	14.22
-070	70	92.08	109.52	120.65	9.53	60.31	1.57	53.98	120.65	19.05	184.15	13.99
-075	75	100.00	104.78	112.71	9.53	63.58	3.96	57.15	134.62	17.78	196.85	19.78
-080	80	109.52	120.65	130.18	9.53	63.50	6.35	57.15	134.62	17.78	196.85	18.31
-082	82	109.52	120.65	130.18	9.53	63.50	6.35	57.15	134.62	17.78	196.85	18.35
-085	85	112.70	127.00	138.10	12.73	63.50	1.57	57.15	146.05	22.23	215.90	16.94
-090	90	112.70	127.00	138.10	11.89	63.50	1.57	57.15	146.05	22.23	215.90	16.94
-095	95	120.65	130.18	138.10	10.33	64.26	2.36	57.15	155.60	22.23	228.60	18.49
-0100	100	127.00	139.70	152.40	10.33	63.50	2.36	57.15	155.60	22.23	228.60	18.00
-0102	102	127.00	139.70	152.40	10.33	63.50	2.36	57.15	155.60	22.23	228.60	18.00
-0110	110	137.80	155.57	165.10	11.61	63.50	2.36	57.15	168.25	22.25	242.57	17.36
-0120	120	142.88	155.58	165.10	10.95	63.65	2.39	57.15	168.28	22.23	242.57	17.39
-0130	130	161.93	187.33	196.85	10.34	63.65	2.36	57.15	199.95	23.88	285.75	16.78
-0135	135	161.93	187.33	196.85	10.34	63.65	1.57	57.15	199.95	23.88	285.75	17.00
-0140	140	165.10	171.45	203.20	9.55	71.44	2.36	63.50	206.36	23.83	292.10	18.59
-0160	160	190.50	214.33	222.25	10.31	69.85	1.60	63.50	228.60	23.81	304.80	14.73

\*Min. Bolt Circle = H dimension + (1) bolt diameter + 1.6mm.  
Bolt Circle = J dimension - 1.6mm.



# TYPE 3710

## Cartridge Split Seal

### Type 3710 Dimensional Data (inches)

Seal Dash Number	A +0.000/-0.002	B		C	D	E	F Set Dim.	G	H	J	K	L Min.
		Min.	Max.	Min.	Min.							
-24	1.500	2.500	2.687	2.937	0.407	1.878	0.063	1.750	3.250	0.625	5.281	0.503
-27	1.687	2.500	2.687	2.937	0.407	1.878	0.063	1.750	3.250	0.625	5.281	0.503
-28	1.750	2.500	2.687	2.937	0.407	1.878	0.063	1.750	3.250	0.625	5.281	0.503
-30	1.875	2.625	2.875	3.125	0.423	2.003	0.063	1.828	3.350	0.562	5.500	0.487
-31	1.938	2.750	3.000	3.312	0.438	2.010	0.063	1.828	3.440	0.562	5.500	0.519
-32	2.000	2.750	3.000	3.312	0.438	2.007	0.063	1.828	3.440	0.562	5.500	0.519
-34	2.125	2.875	3.125	3.625	0.313	2.188	0.063	2.000	3.940	0.656	6.125	0.638
-35	2.188	3.062	3.625	4.000	0.375	2.250	0.063	2.000	4.125	0.750	6.500	0.660
-36	2.250	3.062	3.625	4.000	0.375	2.250	0.063	2.000	4.125	0.750	6.500	0.660
-38	2.375	3.188	3.750	4.125	0.375	2.145	0.063	2.000	4.125	0.750	6.500	0.624
-39	2.438	3.188	3.625	4.000	0.375	2.145	0.063	2.000	4.125	0.750	6.500	0.644
-40	2.500	3.188	3.625	4.000	0.375	2.145	0.063	2.000	4.125	0.750	6.500	0.644
-42	2.625	3.625	3.875	4.250	0.281	2.375	0.093	2.125	4.750	0.750	7.250	0.591
-43	2.688	3.625	4.000	4.250	0.344	2.375	0.093	2.125	4.750	0.750	7.250	0.591
-44	2.750	3.625	4.312	4.750	0.375	2.375	0.063	2.125	4.750	0.750	7.250	0.551
-46	2.875	3.937	4.125	4.438	0.375	2.503	0.156	2.250	5.300	0.700	7.750	0.779
-47	2.937	3.937	4.125	4.438	0.375	2.503	0.156	2.250	5.300	0.700	7.750	0.779
-48	3.000	3.937	4.125	4.438	0.375	2.503	0.156	2.250	5.300	0.700	7.750	0.779
-50	3.125	4.312	4.750	5.125	0.375	2.502	0.250	2.250	5.300	0.700	7.750	0.720
-52	3.250	4.312	4.750	5.125	0.375	2.502	0.250	2.250	5.300	0.700	7.750	0.722
-54	3.375	4.437	5.000	5.437	0.501	2.500	0.063	2.250	5.750	0.875	8.500	0.667
-55	3.437	4.437	5.000	5.437	0.501	2.500	0.063	2.250	5.750	0.875	8.500	0.667
-56	3.500	4.437	5.000	5.437	0.501	2.500	0.063	2.250	5.750	0.875	8.500	0.667
-58	3.625	4.750	5.125	5.437	0.407	2.530	0.093	2.250	6.125	0.875	9.000	0.729
-60	3.750	4.750	5.125	5.437	0.407	2.530	0.093	2.250	6.125	0.875	9.000	0.729
-62	3.875	4.937	5.500	6.000	0.482	2.627	0.093	2.250	6.125	0.875	9.000	0.673
-64	4.000	5.000	5.500	6.000	0.407	2.502	0.093	2.250	6.125	0.875	9.000	0.709
-66	4.125	5.125	5.719	6.062	0.407	2.503	0.093	2.230	6.125	0.875	9.000	0.709
-68	4.250	5.250	5.750	6.062	0.407	2.503	0.093	2.230	6.125	0.875	9.000	0.709
-70	4.375	5.425	6.125	6.500	0.457	2.501	0.093	2.250	6.624	0.876	9.550	0.684
-71	4.437	5.425	6.125	6.500	0.457	2.501	0.093	2.250	6.624	0.876	9.550	0.684
-72	4.500	5.425	6.125	6.500	0.457	2.501	0.093	2.250	6.624	0.876	9.550	0.684
-76	4.750	5.625	6.125	6.500	0.432	2.505	0.093	2.250	6.624	0.875	9.550	0.684
-80	5.000	5.938	6.750	7.250	0.438	2.503	0.093	2.250	7.438	0.813	10.750	0.678
-82	5.125	6.375	7.375	7.750	0.407	2.506	0.093	2.250	7.872	0.940	11.250	0.661
-84	5.250	6.375	7.375	7.750	0.407	2.506	0.093	2.250	7.872	0.940	11.250	0.660
-86	5.375	6.500	7.500	8.000	0.376	2.812	0.093	2.500	8.125	0.938	11.500	0.649
-88	5.500	6.500	7.500	8.000	0.376	2.812	0.093	2.500	8.121	0.938	11.500	0.732
-96	6.000	7.063	8.000	8.500	0.376	2.825	0.093	2.500	8.625	0.938	11.750	0.707
-100	6.250	7.500	8.438	8.750	0.407	2.750	0.063	2.500	9.000	0.938	12.000	0.580
-104	6.500	7.500	8.500	8.875	0.376	2.750	0.093	2.500	9.000	0.940	12.000	0.672
-112	7.000	8.250	9.063	9.375	0.407	2.850	0.063	2.500	9.640	1.000	12.500	0.518
-116	7.250	8.250	9.250	9.625	0.407	2.850	0.063	2.500	9.640	1.000	12.500	0.650
-128	8.000	9.438	10.500	11.281	0.375	3.378	0.093	3.312	11.374	1.125	15.062	0.639

\*Min. Bolt Circle = H dimension + (1) bolt diameter + 1/16".

Max. Bolt Circle = J dimension - 1/16".

**Repair Kits Are Available for All Sizes.**



# TYPE 3710

## Cartridge Split Seal

### Basic Pressure Rating

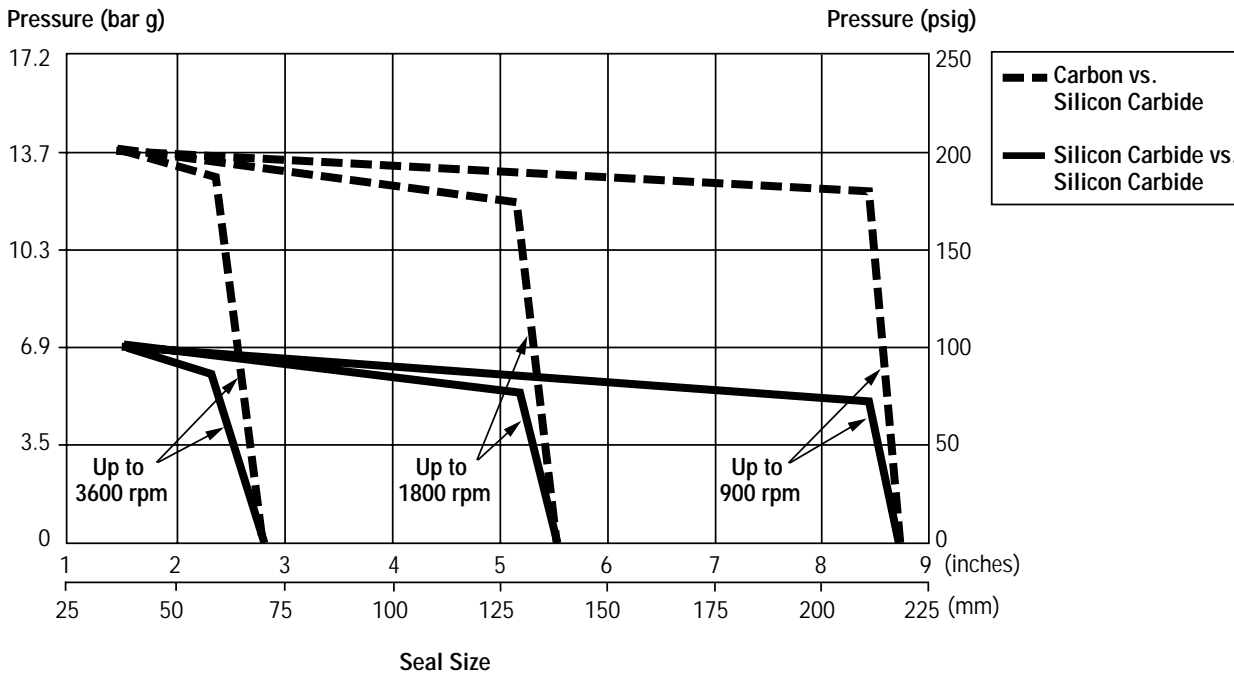

The Basic Pressure Rating is for a standard seal, as shown in the typical arrangement, when installed according to the criteria given in this Data Sheet and generally accepted practices.

The Basic Pressure Rating assumes stable operation at the rated speed in a clean, cool, lubricating, nonvolatile liquid, with an adequate flush rate. When used with the multiplier factors, the Basic Pressure Rating can be adjusted to provide a conservative estimate of the dynamic pressure rating. Contact John Crane for more information.

### Multiplier Factors

	Selection Consideration	Multiplier Factors	
		Carbon vs. SiC	SiC vs. SiC
Temperature*	Up to 80°C/175°F Between 80°C/175°F and 120°C/250°F	x 1.00 x 0.90	x 1.00 x 1.00

#### Example for Determining Pressure Rating Limits:

Seal: 100mm/4.00" diameter Type 3710  
 Product: Brown Paper Stock  
 Face Material: Carbon vs. Silicon Carbide  
 Operating Temperature: 85°C/185°F  
 Operating Speed: 1800 rpm

Using the Pressure Rating Limits graph, the maximum pressure would be 12.6 bar g/183 psig.

From the Multiplier Factors chart, apply the multipliers for the specific service requirements to determine the maximum operating pressure for the application.

$$12.6 \text{ bar g/183 psig} \times 0.90 = 11.4 \text{ bar g/165 psig}$$

At 1800 rpm with the service conditions noted, a 100mm/4.00" diameter Type 3710 Cartridge Split Seal has a maximum operating limit of 11.4 bar g/165 psig. If operating pressure exceeds the pressure limit, consult your John Crane Sales/Service Engineer.

\*The temperature at the seal faces includes the effects of flush and cooling.

CUT LINE FOR SHORT PAGE



# TYPE 3710

## Cartridge Split Seal

### Materials of Construction

SEAL COMPONENTS	MATERIALS
Description	Standard
Seal Faces	Carbon vs. Silicon Carbide Silicon Carbide vs. Silicon Carbide
Hardware	316 Stainless Steel
Mating Ring/Retaining Ring	Alloy X-750
Primary Ring/Retaining Ring	316 Stainless Steel
Spring Retainer	Polymer
Finger Spring	17-7 PH Stainless Steel
Elastomers	Fluorocarbon Ethylene Propylene Rubber (EPR)

### Application Criteria

To determine the appropriate Type 3710 Seal for specific installations, please provide the following information for complete review and evaluation by John Crane Engineering:

- The Equipment
  - Make and Model
  - Shaft or Sleeve OD
  - Seal Cavity Dimensions
  - Shaft Speed
  - Piping Available (if applicable)
- Process Fluid
  - Temperature
  - Seal Chamber Pressure
  - Specific Gravity
  - Viscosity
  - Vapor Pressure
  - Solids/Fibers Concentration

CUT LINE FOR SHORT PAGE



# TYPE 3710

## Cartridge Split Seal

### Recommended Piping Arrangements

#### ANSI Plan 7302 (API Plan 02)

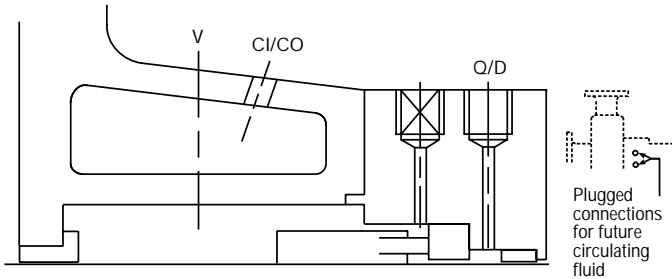

SEAL CHAMBER FOR PLAN 02

Normally specified for clean fluids, this plan calls for a dead-ended seal chamber with no circulation of flush fluid. The seal cavity may be jacketed, and a heating or cooling fluid can be circulated through the jacket. A throat bushing may be required when specified.

#### ANSI Plan 7311 (API Plan 11)

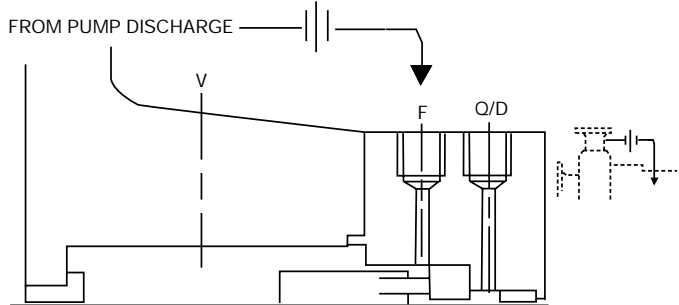

SEAL CHAMBER FOR PLAN 11

This plan requires installation of a recirculation line from the pump case discharge through an orifice to the gland flush connection. The primary purpose of this plan is to dissipate heat generated at the seal faces and/or build seal chamber pressure.

#### ANSI Plan 7313 (API Plan 13)

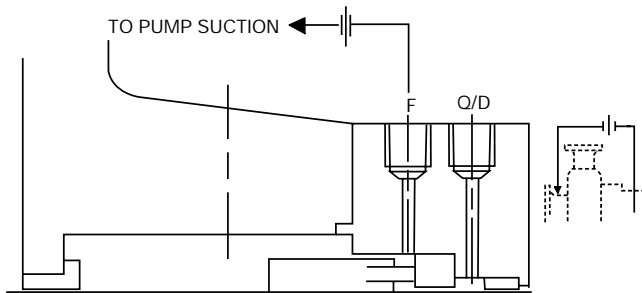

SEAL CHAMBER FOR PLAN 13

This piping plan requires the installation of a recirculation line from the gland flush connection back to the pump suction. ANSI Plan 7313 is frequently used on vertical pumps to vent vapors from the seal chamber. It is also used in applications where the seal chamber pressure is at or near discharge pressure. When utilizing this piping plan on a horizontal pump, the flush connection should be located at the top of the gland to ensure that there are no air pockets in the seal chamber.

#### ANSI Plan 7332 (API Plan 32)

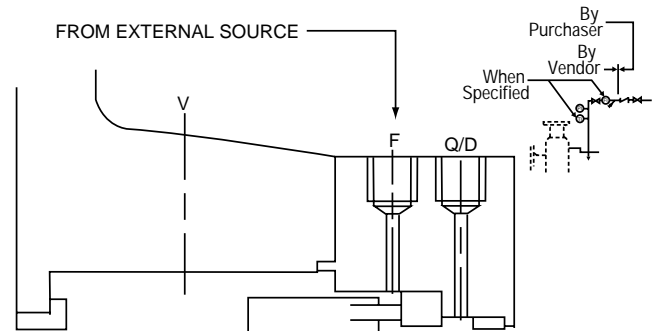

SEAL CHAMBER FOR PLAN 32

ANSI Plan 7332 requires the injection of a clean fluid from an external source to the seal. This flush can help to extend seal life. A close clearance throat bushing can be installed to further isolate the pumped product from the seal chamber and to minimize the amount of flush fluid required.



## John Crane

#### North America

Morton Grove, Illinois USA

Tel: 1-847-967-2400

Fax: 1-847-967-3915

1-800-SEALING

#### Europe, Middle East, Africa

Slough, UK

Tel: 44-1753-224000

Fax: 44-1753-224224

#### Latin America

São Paulo, Brazil

Tel: 55-11-3049-9900

Fax: 55-11-3849-8270

#### Asia Pacific

Singapore

Tel: 65-222-9161

Fax: 65-223-5085

For your nearest John Crane facility, please contact one of the locations above.

If the products featured will be used in a potentially dangerous and/or hazardous process, your John Crane representative should be consulted prior to their selection and use. In the interest of continuous development, John Crane Companies reserve the right to alter designs and specifications without prior notice. It is dangerous to smoke while handling products made from PTFE. Old and new PTFE products must not be incinerated.